

# INSTALLATION INSTRUCTIONS.

## 296 PUSH BAR PANIC LATCH.

### INSTALLATION INSTRUCTIONS

Panic devices manufactured in accordance with EN 1125:2008 will provide a high degree of safety and reasonable security provided they are fitted to doors and frames in good condition. It is not recommended that panic devices be fitted to hollow core doors. The door/doors should be checked to ensure correct hanging and freedom from binding.

This panic latch is reversible to suit both left and right hand doors of upto 1220mm (4'-0") wide.

For double door sets with rebated meeting stiles this panic latch is suitable for use on the first opening door when used together with box keep Cat. No. 300.

The other door should be fitted with a single panic bolt Cat. No. 294.

Unless specially designed by the manufacturer panic devices are not intended for use on double action (double swing) doors.

**WARNING** The safety features of this product are essential to its compliance with EN 1125:2008. No modification of any kind, other than described in these instructions are permitted.

### REVERSIBLE PANIC LATCH

Supplied as standard this panic latch is assembled to suit left hand opening doors. To reverse the assembly to suit right hand opening doors proceed as follows.

1. Remove the panic latch backplate followed by the drive casting and actuating pressing.
2. The latch bolt/blanking casting assembly is reversible in the body by compressing between forefinger and thumb and replacing in the required position.
3. Reverse the position of the actuating pressing on the drive casting. Refit in the latch body ensuring that the drive casting pivot is correctly located and that the drive casting spigot is fully engaged with the latch bolt pressing.
4. Refit the backplate and test for correct operation.

### FITTING PROCEDURE

Text instruction letter also refers to the relevant detail or dimension shown on the diagram.

**A.** Determine the height of the push bar between 900mm and 1100mm from floor level. Mark this position on the jamb adjacent to the door. To establish the mounting position for the panic latch operating unit 10mm from the jamb. Place the template on the door and align the push bar height and the rebate line with the jamb and drill the fixing holes required. Remove the template and fix the operating unit.

**B.** For a single door fit keep plate to the jamb. Note that only the keep face within the jamb rebate should be recessed to provide flush fitting.

**C.** For double doors fit box keep Cat. No. 300 to adjacent (second opening) door. Note the position of the panic bolt unit for this application.

**D.** Operate the panic latch and ensure that the latch bolt moves and returns freely, enters the keep fully and allows the door to be opened easily and closed securely.

**E.** Using the template position the slave unit on the door directly opposite the operating unit and 10mm from the jamb and fix.

**F.** Measure the outside dimension across the operating arms. Subtract 8mm and cut the plain end of the push bar to length. Drill a 10mm dia. hole in the plain end of the push bar on the centre line and 14mm from the end.

**G.** Locate the push bar in the operating arms and ensure that the holes align with the arm clamp screws. Insert the end plugs into both ends of the push bar flush with the operating arms and fully tighten both screws.

**H.** Finally test the panic latch to ensure that when the push bar is operated the door opens immediately and swings freely. When the door is closed ensure that the latch bolt engages fully in the keep and holds the door securely closed.

**I.** Remove backing paper and fit the self adhesive name plates into the recessed location in the body castings to cover the top fixing screws.

Fit green self adhesive "Push Bar to Open" sign onto the door immediately above the push bar.

### MAINTENANCE

**Weekly.** Check for correct operation of the touch bar latch and that the bolt engages fully with the keep. Ensure that the keep is free from obstruction.

**3 Monthly.** Check that all fixings are secure.

### IMPORTANT

This equipment must be installed by a competent installer. These fixing instructions must be supplied to the user by the installer when the installation is complete. If these instructions are disregarded then no responsibility can be accepted by the manufacturers.

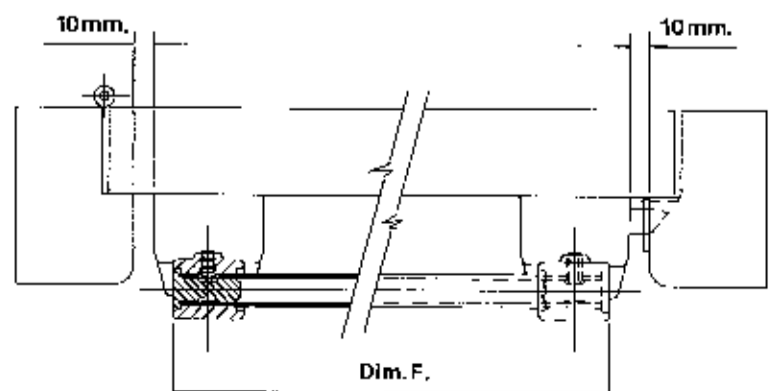
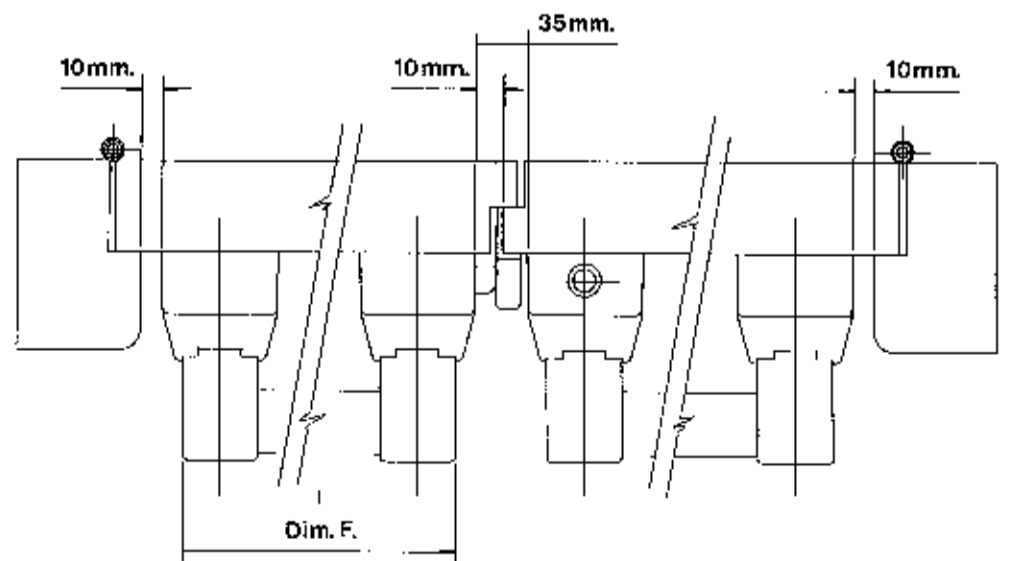
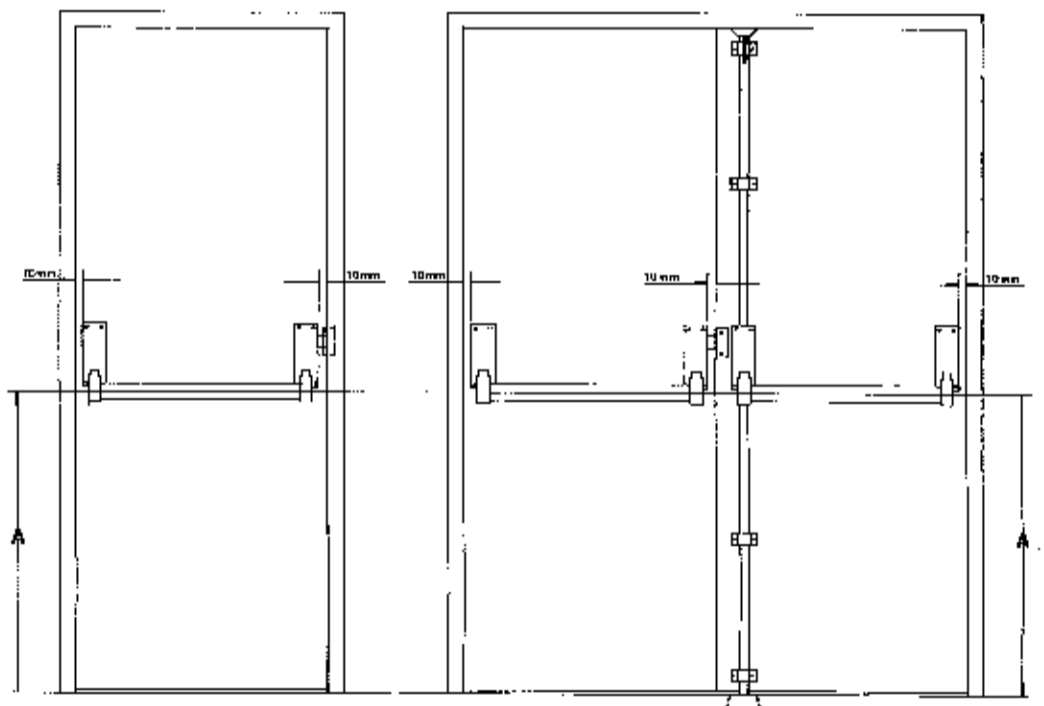
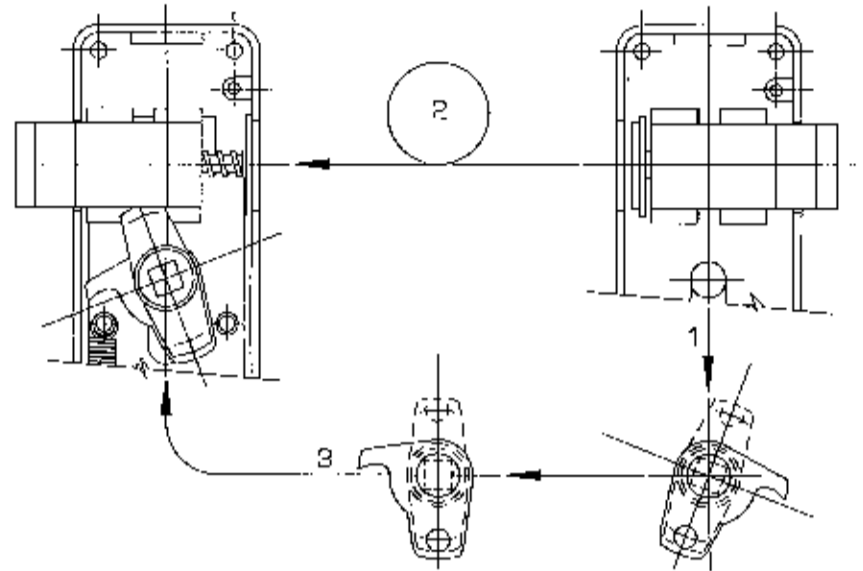

# INSTALLATION INSTRUCTIONS. RIM CYLINDER LOCK OPERATED LATCH.

## INSTALLATION INSTRUCTIONS

Rim Cylinder Lock Operated Panic Latch.

Panic Latch Cat. No. 296 and Push Pad Panic Latch Cat. No. 297 can be operated from outside by a suitable rim cylinder lock.

### FITTING PROCEDURE

**A.** Working on the inside face of the door use the template provided to establish the fixing position for the panic latch as described in the appropriate installation instruction sheet. In addition using the template mark the position of the latch square drive hole on the door.

**B.** To fit the rim cylinder lock using the backplate supplied with the lock. Bore a 32mm dia. hole through the door noting the correct relationship between the rim cylinder lock body and the square drive hole in the panic latch.

**C.** To fit the rim cylinder lock without using the backplate. Mark the position of the rim cylinder lock on the outside face of the door in the correct relationship to the square drive hole in the panic latch. Bore a 32mm dia. x 28mm deep hole. Working on the inside face of the door drill the cylinder lock/panic latch drive hole 10mm dia. through in the position previously marked. Drill two cylinder lock mounting holes 6mm dia. c'sk. 9mm dia. for fixing screws.

**D.** Cut the mounting screws to length and temporarily fit the cylinder lock to the door. Mark the drive tongue to provide 13mm projection from the door face. Remove the cylinder lock, cut the drive tongue to length and refit securely.

**E.** Fit the cylinder lock adapter into the square drive hole in the latch to form a slot. Locate the drive tongue into the slot and fit the latch unit.

**F.** Check for free and correct operation of the rim cylinder lock and the panic latch/panic pad panic latch.

### IMPORTANT

This equipment must be installed by a competent. These fixing instructions must be supplied to the user by the installer when the installation is complete. If these instructions are disregarded then no responsibility can be accepted by the manufacturers.

